



BETTER IN BULK

Systems & Components for Dry Solids Handling



 **tbma**

www.tbma.com

SAMPLING • DOSING • MIXING • STORAGE • CONVEYING • DEDUSTING • DISCHARGING • FILLING • ENGINEERING

Better in Bulk

TBMA is an international engineering organisation based in Holland with sales representation and service facilities across Europe and Asia. TBMA are specialists in Powder Handling and Process Engineering for the design, supply, installation and commissioning of components and automatic process plants to a variety of industries.

All TBMA systems and components are designed and delivered according ATEX 95 guidelines.

Strong performance, Solid partners

TBMA have designed and developed an extensive range of standard processing equipment with proven reliability in practice. In addition to her own product range, TBMA represents a number of high quality manufacturers and markets their associated products like dosing feeders, bulk loading spouts, sampling equipment etc. This complete range of standard processing equipment offers you, in most cases, a quick and direct solution to your problems.

Custom Engineering

If you have special demands or if you are unsure if our standard processing equipment can meet your specifications, TBMA can offer you a complete test facility for assessing customer requirements before making appropriate recommendations on the equipment required for any future installation. With its sophisticated systems and bulk handling equipment, TBMA have successfully completed turn-key projects in the chemical, paints, ink, food, plastic, cement, dairy and compounding industries. Installations have called for design and manufacture of equipment for storage, conveying, dosing, feeding, discharging, weighing, dedusting, and mixing of solid raw materials and associated products.

Quality is no Coincidence

Expertise in the application of equipment with proven reliability in practice plus an extensive range of quality standard processing machines will provide you with the guarantee of high performance. For many companies it is this professional attitude that has been the main reason to choose TBMA as their partner. It is our business to look for a solution to your process problems.



TBMA can make the difference. Contact us and find out!!

Pneumatic Conveying

Pneumatic conveying is a TBMA speciality. In this area there are many different system possibilities. TBMA can offer you an excellent solution for dilute phase (low and medium pressures in either vacuum or pressure execution) and dense phase (high pressure conveying). All conveying systems can be supplied in "Closed Loop" executions.

The TBMA programm ranges from high quality pneumatic components like rotary valves, diverter valves, pressure vessels, blowers and material handling fans up to complete pneumatic conveying installations for various conveying capacities and distances.



■ Dilute phase conveying of titanium dioxide

Low / medium pressure conveying systems (Dilute Phase)

Dilute phase pneumatic conveying installations are suitable for most bulk powders and granulates.

Specific characteristics are:

- From one source to one or more collection points
- Suitable for non or mildly abrasive products
- Low pressure / high conveying velocity
- Conveying velocity 15-30 mtr/sec.
- Conveying pressure up to 1 bar
- Relatively low installation costs



■ Vacuum conveying of colour additives / pigments

Vacuum conveying systems

Vacuum conveying systems for various capacities over limited distances. Ideally suited for the conveying of powders and granulates with the following specific characteristics:

- From one or multiple sources to one collection point
- No product leakage due to underpressure
- Suitable for toxic or harmful products
- Conveying pressure up to -0,5 bar



■ Dense phase conveying of foundry sand

High pressure conveying systems (Dense Phase)

Dense phase pneumatic conveying systems for various conveying capacities and distances.

Conveying is realised by special designed TBMA pressure vessels with the following specific characteristics:

- Suitable for abrasive and friable products
- High pressure / low conveying velocities
- Conveying velocity 2 - 10 mtr/sec.
- Conveying pressure up to 6 bar
- Batch or continuous conveying
- Minimal product damage
- Reduced erosion of conveying line
- Longer conveying distances are possible
- Reduction of blocked line possibilities

Rotary valves and blowing seals

Rotary valves are an essential part of your process equipment for pneumatically conveying or dosing powdered and granulated materials. TBMA are able to build on a wealth of experience in the application of rotary valves in many fields of the process industry. The result being an extensive size range of rotary airlocks and blowing seals with numerous execution possibilities. This may vary from a simple dust valve to a valve handling product of a critical nature. All rotary valves are ATEX 95 certified.

High-Duty

TBMA High-Duty rotary airlocks and blowing seals are employed in the conveying and dosing of almost any kind of product in the most demanding applications. These valves are eminently suitable for handling powdered and granulated materials in pneumatic conveying systems and under atmospheric conditions. All H-AR type rotary valves can be employed as a protective system up to 10 bar (dust explosion barrier).



Rotary Airlocks Type H-AR

- Flange size DN 150 - 500 (circular)
- Rotor volume 2,5 - 125 ltr./rev.
- Outboard, dust-tight ball bearings
- Max. operating pressure differential 1,5 bar



Blowing seals Type H-GR

- Flange size DN 150 - 350 (circular)
- Rotor volume 2,5 - 58 ltr./rev.
- Outboard, dust-tight ball bearings
- Max. operating pressure differential 1,5 bar



Rotary Airlocks Type H-AX

- Flange size DN 150 - 350 (square/circular)
- Rotor volume 2,5 - 34 ltr./rev.
- Outboard, dust-tight ball bearings
- Max. operating pressure differential 1,5 bar

Medium-Duty

The TBMA R-AX and M-AX type rotary airlocks have been specially designed to offer a suitable and economic solution for standard applications with a limited pressure differential. These valves are used for example in dosing/discharging non-abrasive materials in pneumatic conveying systems or mounted below powder hoppers for abrasive or mildly cohesive products.



Rotary Airlocks Type R-AX

- Flange size DN 150 - 350 (square/circular)
- Rotor volume 2,5 - 34 ltr./rev.
- Outboard, dust-tight ball bearings
- Max. operating pressure differential 1 bar
- Quick demountable motor



Rotary Airlocks Type M-AX

- Flange size DN 150 - 350 (square/circular)
- Rotor volume 2,5 - 58 ltr./rev.
- Outboard, dust-tight ball bearings
- Max. operating pressure differential 1 bar
- Quick demountable motor



"Smart-Lite™" Dust valve Type S-AX

- Flange size DN 250 (square/circular)
- Rotor volume 9,5 ltr./rev.
- Inboard, dust-tight ball bearing
- Max. operating pressure differential 0,5 bar
- Explosion proof up to 3 bar (option)

Special-Duty

A totally different rotary valve which can be used for continuous, controlled discharge and dosing of virtually all products stored in silos or hoppers. It can be readily applied to feed products into pneumatic conveying systems with no resistance to flow from air leakage through the valve. Horizontal rotary valves combine a large inlet area with a relatively small rotor volume. Even poor flowing products susceptible to bridging and rat holes can be discharged accurately at high rates by fitting specially designed agitators to the vertical rotor shaft.



■ Horizontal rotary valve Type HZA/HZF

Horizontal Rotary Metering valve Type HZ

- Type HZA: for gravity feed applications
- Type HZF: for feeding into pneumatic conveying systems

Specific features

- Feed rate: 3 l/h - 100.000 l/h
- Flange size: DN 150 tot DN 700
- Large inlet area with connection flange DIN 2502 / PN 10
- No resistance to flow from air leakage through valve
- Product agitators available for poor flowing materials
- Highly accurate and repeatable dosing characteristics
- Pulsation-free feed of the product

Diverter valves

Diverter valves are an essential part of pneumatic and gravity feed conveying systems. TBMA has an extensive range of various diverter valves, which meet the most stringent demands set by industry concerning working safety and reliability. It is therefore possible to offer a suitable solution for a wide range of materials in a variety of working environments.



Below you will find a global review of the TBMA diverter valve range:

- Two-way diverter valve flap type
- Dual-channel plug diverter valve
- Single-channel plug diverter valve
- Ball type diverter valve
- Gravity feed diverter valve



Shut-off valves

Within our range of bulk handling equipment TBMA offers an extensive range of shut-off valves, suitable for the control of product flow to or from silos, hoppers, bunkers, mixers etc. for a variety of products and applications.



Below you will find a global review of the TBMA valve range:

- Slide valve
- Plate type slide valves
- Swing type slide valves
- Bunker slide valves
- Knife-gate valves
- Butterfly valves
- Ball valves
- Pinch valves
- Non-return valves



Mechanical conveying systems

For the discharge, dosing and conveying of powders and granulates from silos, hoppers, bag emptying systems etc. a wide range of mechanical conveying systems are available from TBMA having many different application possibilities.

Conveyors can be mounted horizontally, at an angle or vertically from and to various loading and discharge points. It is also possible to use screw conveyors for cooling, heating and mixing.



Big-Bag Handling

Optimum handling of FIBC's

The transport and delivery of raw bulk materials is more often being done by means of F.I.B.C.'s, (Flexible Intermediate Bulk Container) or Big-Bags. In order to fully benefit from the advantages that Big-Bags have to offer it requires well-designed systems that effectively fill and empty these Big-Bags. TBMA has a wide range of expertise in the application of this type of equipment with proven reliability in practice that is essential for a correct assessment of the right type of system for your particular situation

Big-Bag filling- and weighing systems

Efficient filling and high accuracy weighing

TBMA can offer you a modular range of Big-Bag systems whereby the basic models can be extended with several options to obtain a complete solution for filling and weighing Big-Bags. With these modular systems unstable, poorly filled and unstackable bags belong to the past.

Complete range with smart options like:

- Hang weighing
- Filling capacities up to 70 bags per hour
- Ergonomic operation for hanging bags by means of rotating filling head
- Compaction by special designed coned vibrator table
- Filling spout with inflatable clamping mechanism
- Automatic liner inflation with air exhaust jacket
- Certified weighing system by three tension load cells
- Fully automatic pallet supply and filled bag removal



■ Big-Bag filling system for handling resin flakes



■ Big-Bag weighing- and filling system Model VB2



■ Big-Bag discharger Model LB2 with rigging frame, outlet spout and screw conveyer



■ Big-Bag discharger Type LB1 with Gantry

Big-Bag discharging systems

Big-Bag discharging systems are specifically designed for discharging a large variety of products from different types of Big Bags. They eliminate dust emissions, product loss or product contamination. This modular range encompasses the discharge of single or multi-trip bags, with or without plastic liner.

Many options and execution possibilities:

- Flat- or conical discharge hopper
- Dust free discharge by means of rubber dust membrane
- Vibration motor for efficient discharge of product
- Liner tensioning and clamping mechanism
- Suitable for different bag sizes
- Containment enclosure for handling toxic or hazardous products
- "Dropstop" to safely tie off and remove partially emptied Big-Bags



TBMA can offer you a complete test facility for assessing customer requirements before making appropriate recommendations on the equipment required for any future installation.

Bag emptying

Manual emptying and handling of bags is very labour intensive and can generate an unacceptably high dust level. Many of the products handled can be dangerous if inhaled or if they come into contact with the skin. It creates a working environment with serious health dangers resulting in a lowering of operator efficiency and production capacity. A well designed bagslitting and discharge unit is therefore essential. TBMA offer you several fine solutions for dust free and labour saving handling of almost all single or multi-layered bags whether they be paper, plastic, large, small, densely- or lightly-filled.

Perfect solution for all your bag discharge problems

- Manual, semi-automatic or fully automatic intake of bags
- Batch or continuous handling
- Minimal residue
- Capacities up to 2000 bags per hour
- Large range of ancillary equipment

Fully automatic bagslitting and emptying machine Type "GALAHAD"

The "Galahad" automatic bagslitter is suitable for the continuous and dust-free handling of all types of single or multi-layered bags. Depending on the execution, properties of the product and the condition of the bags, capacities can be reached up to 2000 bags per hour. The "Galahad" unit can be enhanced in to a complete automatic baghandling installation by utilising a wide range of standard accessories.



■ Processing installation for pigments and fillers using an "Galahad" automatic bag-emptying machine complete with scissor lift, baling press and filter installation



■ Manual Sack Tipping unit



■ "Bags-to-Bulk" system for plastic granules and powders incorporating "Galahad" automatic bag emptying machine.

Efficient bag handling

The method of operation is simple but very effective. It ensures that the bags are emptied with minimal residue (0,01% - 0,1% for free flowing products). By the appropriate design, the "GALAHAD" can be operated by one man only and offers you an economic solution for your bag emptying problems.



Manual Sack Tipping unit

An ergonomic and dust-free solution for manually discharging plastic and paper bags. It offers a better working height for sack infeed in combination with dust free operation.

The modular set-up of the range offers you several optional features like waste sack compactor and integrated dust removal to suit every application.

Mixing equipment

Turbo mixer/high speed disperser

The Turbo mixer is specifically designed for the efficient mixing, homogenising and volume dispersing of powders in liquid media, particularly where effective solids wetting and fine dispersion are required at comparatively low energy input levels.

With its height adjustable dispersion disc and mixer scraper the Turbo mixer is especially suitable for dispersing temperature sensitive materials like colour additives in paint or PVC compounds.

Important features:

- Closed system, suitable for full vacuum and over pressure.
- Low energy input levels.
- Automatic height adjustment of dispersion disc.
- Conical execution for variable batch sizes
- Heating- or cooling jackets available
- High dispersion efficiency
- Minimum dispersion time

The Turbo mixer can handle viscous liquids up to 25.000 cP at solid contents up to $\pm 80\%$. The mixer is designed and manufactured according to PED guidelines for full vacuum and pressures up to 6 bar.

All turbo-mixers can be executed with the option whereby light pigments and additives can be drawn into the vessel below the liquid surface to achieve good wetting out coupled with minimum dispersion times. Examples of their application are in the manufacture of paint and lacquers, polymers, printing inks, adhesives, resins, coatings and other viscous products.

Vertical mixer / homogeniser

Suitable for the mixing and homogenising of free-flowing products with different particle sizes and bulk densities.

The design of the VRM mixer is based on the principle of creating multiple mass flows within the mixing vessel. The products to be mixed are first conveyed upward by a screw mounted in a central mixing tube. The tube is fitted with one or more mixing heads. At each mixing head and at the top of the mixing tube the product is partially discharged into the descending product flow.

This system, in combination with the angle of the mixing head and vessel cone, creates separate mixing zones resulting in a highly efficient mixer.

Important features:

- Very short mixing cycle
- Low energy input level
- No segregation
- Large mixing capacities
- Easy installation in existing silos and hoppers
- Suitable for drying, cooling and degassing

Capacities from 500 to 10.000 litres

Capacities from 500 to 100.000 litres

Vertical conical screw mixer

This unique conical mixer is equipped with a double helix mixing unit well suited for various mixing, homogenising- and granulation batch processes. The range of applications reaches from free flowing, dry bulk materials to cohesive and moist powders all the way to wet cakes and slurries.

A double helical ribbon agitator mounted in the vessel, transports the product upward along the outer wall.

The helix simultaneously mixes the product and prevents deposits on the wall. In the centre of the vessel the product flows down to be picked up again at the bottom and returned to the mixing process.

The simple construction with drive components kept out of the product area guarantees low maintenance and reliability. Product discharge is complete, facilitated by the moving agitator and the absence of a lower bearing.

Capacities from 20 to 25.000 litres

Horizontal mixer for batch or continuous operation

Turbulent and distributive mixer with product specific paddle designs.

Their mixing action is based on turbulent flow in a mechanically induced fluid bed or alternatively in agitated bulk. Both types are suited for gentle homogenising, for preparation of powder mixtures, and solid/liquid or even pasty mixtures

Batch mixer capacity: 100 to 30.000 litres
Continuous mixer capacity: 0,1 to 1000 m³/h

Silo's and Silo discharge equipment

Silo's, Tanks and Hoppers

TBMA can offer you a complete solution for any kind of storage for dry solids materials. Expertise in the application of equipment and a close cooperation with a selected group of high quality silo and tank manufacturers will provide you with the guarantee of reliability and high performance.



Silo discharge equipment

Silo discharge equipment is used with products that have such bad flowing characteristics that gravity alone is not sufficient to make them flow from the silo, tank or hopper. As a result, typical flow problems occur such as clinging, arching, bridging and rat holing. Both aeration and mechanical systems can be supplied by TBMA in order to restore flowability.



Silo weigh- and level control equipment

In order to maintain a reliable control over silo and tank content level, TBMA can supply you with several types of silo weighing modules or level control sensors.

Bulk loading spouts

Dust-free outloading

When loading bulk products into trucks, ships or stock piling, there is often a heavy generation of dust. This dust generation is a hazard to personnel as well as the environment. Furthermore it entails a considerable loss of product and extra costs for cleaning and maintenance.



TBMA can offer you an extensive range of dust-free outloading solutions suitable for any loading task like ship-, train-, tanker- or truck loading. By using TBMA loading spouts the dust hazard of bulk loading is reduced efficiently. A large line of products is available within dust-free loading systems consisting of telescopic tubes, bellow feeders, filter bellows, and specially developed equipment to suit the materials and capacities to be outloaded. It handles a large range of products from cement, lime, fly ash, plastic granules, coal up to grain, flour, sugar etc. for stock piling, ship, road and rail tanker loading.

The main features in short:

- Unique modular construction with many standard executions
- With or without built-in filter
- Extensive product range
- Short time of delivery
- Easy maintenance
- More than 35 years experience
- Capacities from 0 to 3000 m²/h

■ Bin activator



■ Silo discharge system with fluidisation and rotary valve

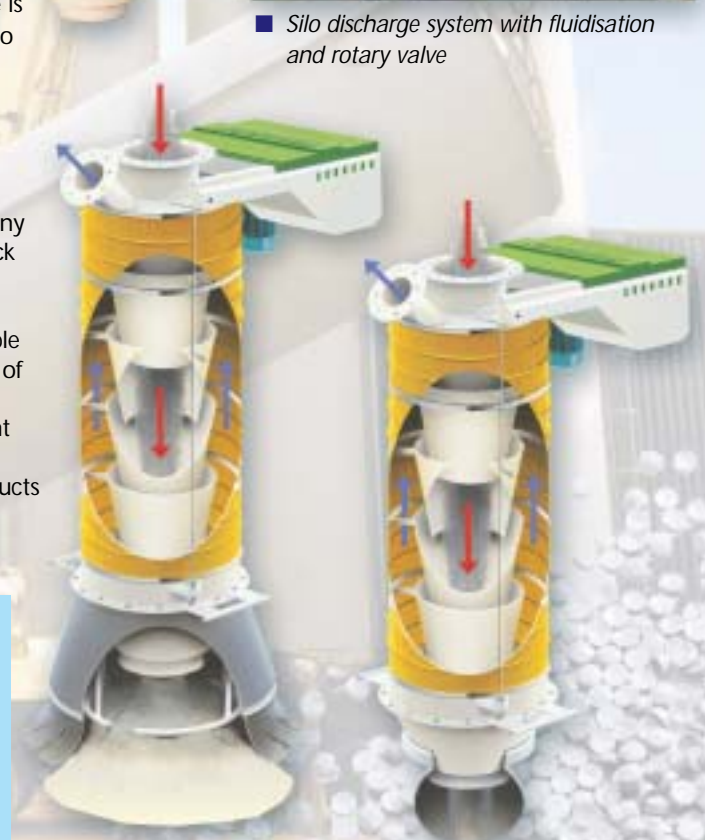

■ Closed loading

■ Open loading

Filters and Dedusting equipment

Each production process involving the handling of powdered and granulated raw materials must comply with the most stringent standards concerning environment, safety and operating efficiency. This demands the application of high quality dedusting equipment



TBMA can offer a range of environmental products for the control of airborne dust particles and the separation of particulate products from conveying air streams. The product line ranges from simple standard package filters and cyclones to purpose built dust control systems.

■ Reverse Jet Filter 6 m² with fan assisted header.



■ Filter-Separator 15 m² for the handling of Methyl cellulose powder and granulate.

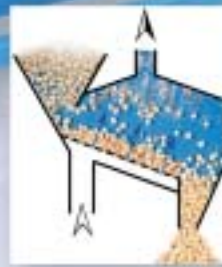

■ Ionic gravity deduster and separator

TBMA's range of dedusting equipment can offer the following options:

- Mechanically cleaned type filters
- Reverse Jet filters
- Cartridge filters
- Cyclones/Separators
- Ionic gravity deduster/separator
- Complete dedusting installations

Sentry-Gustafson Sampling equipment

Reliable quality control

Your company may be spending a lot of money each year on personnel and laboratory equipment to test and analyse your materials, only to find that the sample material you have been studying is not a correct, representative product sample. A correct sample gives all elements in the batch to be sampled. A bad or inconsistent sample means re-sampling and lost time. This can result in discarding an entire batch, costly production losses, shipping delays or rejected shipments.



■ Automatic sampling from pneumatic conveying systems



■ Model RPG with 2-way changeover sampling system



■ Automatic sample collection system

For dependable quality control, TBMA offers you a complete line of automatic sampling systems. These samplers will give you and your customer a consistent, representative product sample of what you receive in bulk, process in plant, or ship. Products sampled include granules (homogeneous and non-homogeneous), flakes, powders, pellets, slurries and liquids. Automatic samplers are capable of taking accurate samples from dilute or dense phase pneumatic conveying lines, positive or negative, vertical or horizontal, tanks, silo's, bins, gravity chutes, etc.



■ Cross-cut sampler for vertical spouts or chutes

Volumetric and Gravimetric dosing feeders

"High Performance" equipment for dry bulk solids metering and dosing

TBMA represents Acriston Int. with its extensive range of both volumetric metering and gravimetric metering systems for the precise metering of dry solid ingredients. Quite simply the utilisation of one metering mechanism design is not sufficient to cope with the diverse nature of dry bulk solids. Therefore four basic designs have been developed with the ability to handle a greater variety of materials, more precisely and more consistently to provide ultimate performance reliability.

- **AI-105 & AI-140 feeder series**
Dissimilar speed double concentric augers mechanism.
Suitable for a wide variety of materials

- **AI-BDF feeder series**
Dissimilar speed triple augers mechanism. Suitable for the most difficult non-free flowing materials

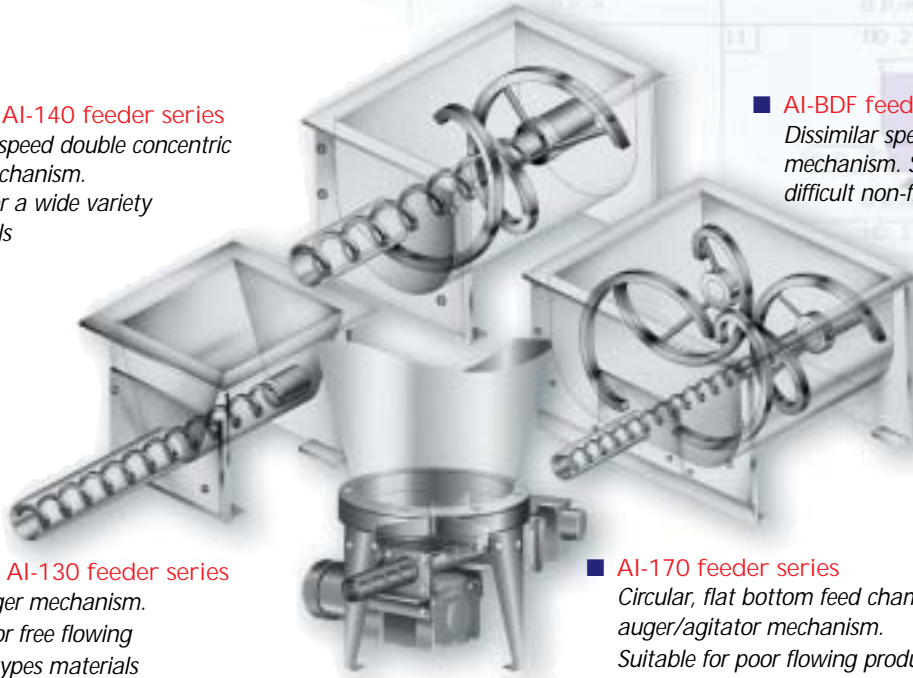

- **AI-101 & AI-130 feeder series**
Single auger mechanism.
Suitable for free flowing granular types materials

- **AI-170 feeder series**
Circular, flat bottom feed chamber with self-emptying auger/agitator mechanism.
Suitable for poor flowing products and rapid product changeovers



- **Model 270 feeder series**
"Inline" weigh feeder
Capacity range up to 155.000 ltr./h

Unique weighing system

Acriston's Weight-Loss Weigh Feeders feature a unique weighing system specifically designed for weight-loss applications in the industrial environment. Their reliability, durability and digital weight-sensing precision are unmatched in the industry.

Advanced technique

The various models of the Acriston feeders basically consist of a positive-flow dry solids feeding/hoppering mechanism, or a positive displacement liquid pump as an integral part of a precision weighing system. Here the rate of product discharging out of the feeding mechanism is precisely controlled on a weight-loss basis by an advanced multiprocessor controller. Performance-proven in thousands of installations throughout the world, and with a history of near-zero maintenance requirements, these technologically advanced weighing mechanisms provide users with complete operational dependability.



- **Model 170 feeder series**
Volumetric feeder for dry solids.
Capacity range up to 6800 ltr./h

Feeder controls

The desired flow rate can be completely controlled with a wide variety of advanced control units including digital weigh processor and feedback control system. The feeder control units can be operated as an individual stand-alone device, or can be operated under the control of a remote master or DCS systems. From their unique operating software and graphics touch screens, to the latest in interfacing capabilities, these controllers offer users cutting edge technologies for optimum weigh feeder performance.

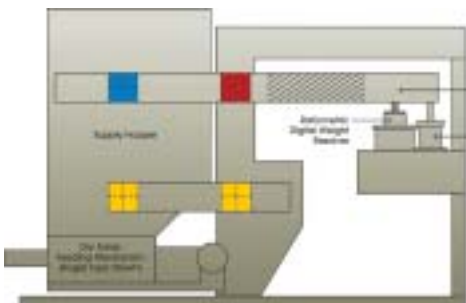

- **Schematic view of overhead scale mechanism with Ratio Digital Weight Resolver**

BETTER IN

Dosing and Weighing

Storage and Discharge

Mixing and Homogenising

Dedusting and Separation

Big-Bag filling and discharging

Bagslitting and Emptying

Mechanical Conveying

Pneumatic Conveying

TurnKey projects

Engineering

Sampling

www.tbma.com

For more information

 **tbma** europe bv

 **tbma** belgië bvba