



# **OMC SERIES**

**Open-mouth  
bagging carousels**

# Bagging carousel

**CHRONO-BAG™ OMC SERIES open-mouth bagging carousels** are suitable for bagging powdery bulk materials such as flour and other fine materials that need to be densified or compacted. Many companies in the flour industry have optimised their packaging processes with Premier Tech Chronos's carousel bagging systems and benefited from many years of reliable operation with this proven bagging system. The design flexibility permits

## Features and benefits

- Ability to handle different types of bag
- Solid construction
- Easily interchangeable bag spouts
- PLC control system with user-friendly operator interface

## Functionality

CHRONO-BAG™ OMC-4055 is a 4 spout carousel. The bag is manually placed on the pneumatically actuated bag clamp, which holds the bags tightly during the following process steps. The first spout is the placing position. The carousel is turned to the next station, which is the filling and first densification position. The bulk material is weighed by a nett weigher and discharged into the bag. The bulk material in the bag is briefly compacted by a vertical passing device. The process is repeated at the next position. At the last position the bag is released from the bag spout, dropped onto a conveyor belt and transferred in upright position into the bag closing device.

With the OMC-4055 outputs of up to 550 bags per hour can be achieved. CHRONO-BAG™ OMC-6090 bagging carousel is equipped with 6 spouts. The procedure is the same as for OMC-4055 however the OMC-6090 utilises 3 passing devices. The OMC-6090 design is a high-speed bagging carousel capable of packing up to 900 bags/hour

## Options

- Sweeping device in carousel area
- Powered height adjustment of the outfeed conveyor
- Automatically adjustable passing device
- Automatic bag placer

quick and simple bag spout changeover. The solid steel construction with low-maintenance components and assemblies guarantees high machine operational availability. The carousel bagging systems are available in manual and semi-automatic versions. On the semi-automatic version, the bag is manually placed on the bag spout and fed automatically into the sewing unit.

- Precise nett weighing technology using the SpeedAC controller
- Low-maintenance components and assemblies
- Clean working conditions due to limited dust escape in the filling area

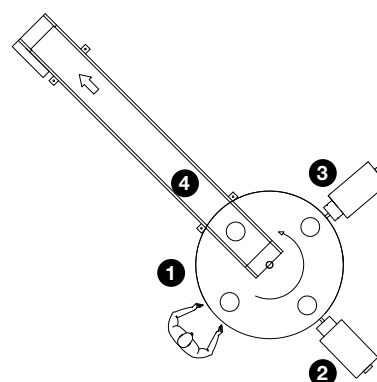

OMC-4055 operation

- 1 Bag placing
- 2 Filling, Possing
- 3 Possing
- 4 Bag release

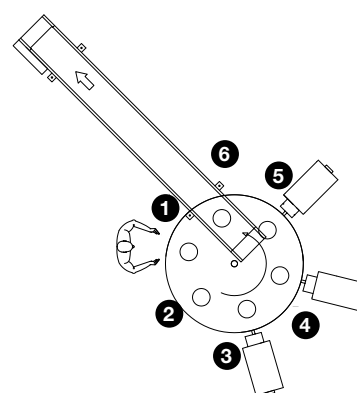

OMC-6090 operation

- 1 Bag placing
- 2 Filling
- 3 Possing
- 4 Possing
- 5 Possing
- 6 Bag release

## Production rate

### OMC-4055

Up to 550 bags per hour\*

### OMC-6090

Up to 900 bags per hour\*

\*Depending on feeder type, bag holder type, product characteristics, bag size, speed, operator skill, etc.

## Technical data

	OMC-4055	OMC-6090
<b>Bag types:</b> .....	Open-mouth bags, pillow type.....	Open-mouth bags, pillow type.....
<b>Bag materials:</b> .....	Paper, PE or PP.....	Paper, PE or PP.....
<b>Bag sizes:</b> .....	Width: 430 – 600 mm Length: 600 – 1200 mm.....	Width: 430 – 600 mm Length: 600 – 1200 mm.....
<b>Weighing technology:</b> .....	One nett weigher.....	Two nett weighers.....
<b>Electrical requirements:</b> .....	3 AC / 400V / 50Hz (other voltages available).....	3 AC / 400V / 50Hz (other voltages available).....
<b>Operating pressure:</b> .....	6 bar.....	6 bar.....
<b>Ambient temperature:</b> .....	+5°C to +35°C.....	+5°C to +35°C.....
<b>Noise level:</b> .....	<75 dB (A).....	<75 dB (A).....



The empty bag is placed onto the spout



The bag is filled and passed



The filled bag is released onto a belt conveyor



The bag is transferred in the upright position into the bag closing device

## Typical layout (with nett weigher)

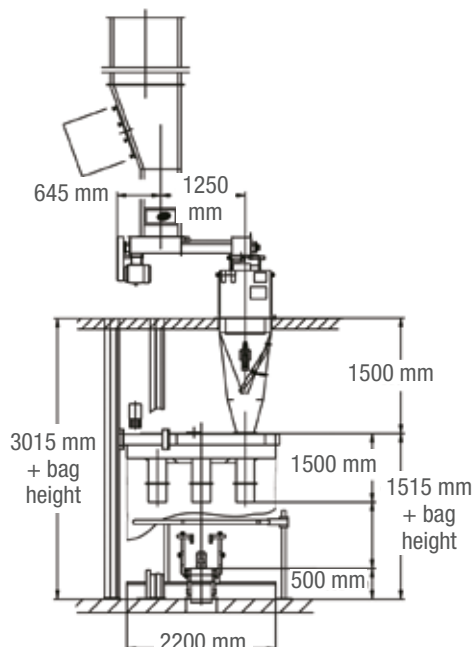
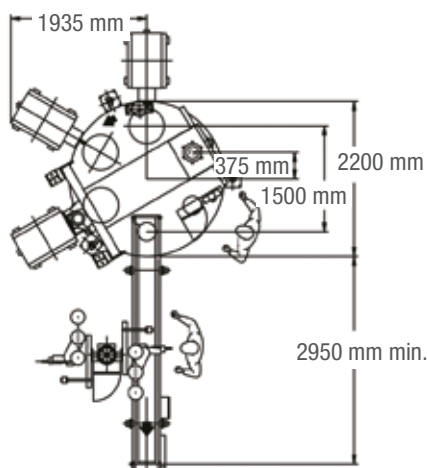

## European Head Office

Premier Tech Chronos B.V.  
Meerheide 40  
5521 DZ Eersel  
THE NETHERLANDS  
☎ +31 (0) 497 514 988  
info-eu@ptchronos.com

## European Regional Offices and Manufacturing Plants

Premier Tech Chronos S.R.L.  
Parma, ITALY  
☎ +39 0521 29 60 11

Premier Tech Chronos Ltd.  
Nottingham, UNITED KINGDOM  
☎ +44 (0) 115 935 1351

Premier Tech Chronos GmbH  
Hennef, GERMANY  
☎ +49 (0) 2242 9335 0

Premier Tech Chronos S.A.  
Longjumeau, FRANCE  
☎ +33 (0) 1 60 11 31 32



The information contained in this brochure is based upon the latest information available at the time of publication and is designed to provide you with a general introduction to our products. We make no warranties or representations as to its accuracy. We are continually updating and improving our products and reserve the right to amend, discontinue or alter specifications and prices without prior notice. Premier Tech is a registered trademark of Premier Tech Ltd © Premier Tech Ltd. 2013

**PTCHRONOS.COM**